

EVOLUTION

PM5

PILE DRIVING  
RIG



Junttan

New Evolution Series

# PM5

## The New Benchmark in Pile Driving

The new Junttan PM5 pile driving rig – the first driven-pile machine in the Junttan Evolution series – pushes the boundaries of performance and user experience to the next level. With best-in-class capacity, state-of-the-art features, and seamless transportation, it represents the new principles of the Evolution series.

The optimized kinematics and an improved component layout deliver class-leading capacity while maintaining low ground pressure. Thanks to Junttan's new telescopic mast design, the PM5 meets the demands of extremely long vertical piles while also enabling steep inclinations with shorter leader configurations.

A completely new Junttan-designed measurement system and intelligent operator assistance features provide consistent quality and reduce operator workload. The Evolution series user interface excels at keeping the operator informed of the data that matters most, including real-time process information, pile driving visualization, diagnostics, and continuous machine-status feedback.



### Features

- ✓ Class-leading performance and capacity
- ✓ Transported as a complete, work-ready unit
- ✓ Fast, effortless rig setup via remote control
- ✓ Premium Evolution series cabin and operator interface for an exceptional user experience



### Technical data

#### LEADER

TYPE		PM 5
LENGTH	STANDARD LEADER SECTIONS	15 + 3,5 + 4 m (49 + 11,5 + 13 ft)
	TOTAL LENGTH	29,3 m (96 ft)
MAXIMUM CAPACITY		25 000 kg (55 100 lbs)
MOVEMENTS	VERTICAL	5 000 mm + 1 500 mm (197 + 59 in)
	HORIZONTAL	1 500 mm (59 in)
INCLINATIONS	ACCORDING TO SEPARATE CAPACITY TABLES	18,4° forward / 15° side / 45° backwards

#### UPPERCARRIAGE

WINCHES	SINGLE LINE PULL, 1 <sup>ST</sup> LAYER	
	HAMMER	20 000 kg (44 000 lbs)
	PILE	13 000 kg (28 660 lbs)
ENGINE	AUXILIARY	10 000 kg (22 046 lb)
	TYPE	VOLVO TAD1382VE
	MAX POWER	315 kW (428 hp)
HYDRAULIC SYSTEM	FUEL TANK	700 l (185 gal)
	MAX FLOW	2 x 290 + 160 l/min (2 x 77 + 42 gal)
	MAX PRESSURE	380 bar (5 511 psi)
COUNTERWEIGHT	OIL TANK	780 l (206 gal)
	FIXED	Max. 4 x 3000 kg (6 600 lbs)

#### UNDERCARRIAGE

CRAWLER LENGTH		5 640 mm (222 in)
WIDTH (900 SHOES)	MIN.	3 380 mm (133 in)
	MAX.	4 880 mm (192 in)
TRACK SHOES	WIDTH	900 mm (35 in)

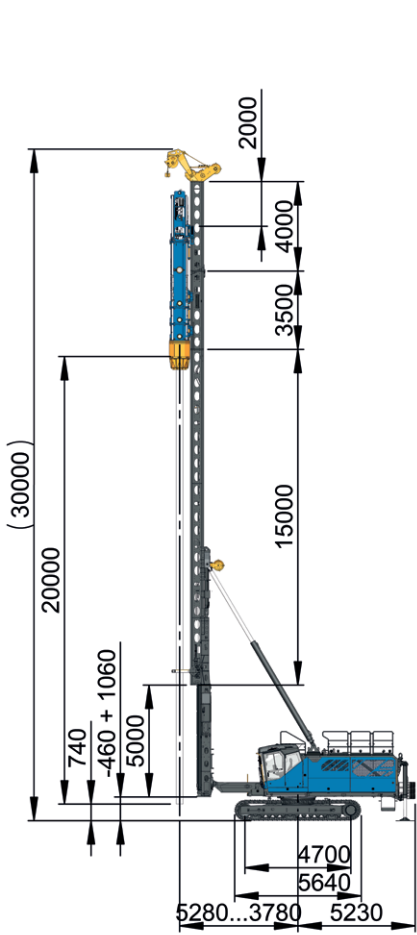

STANDARD

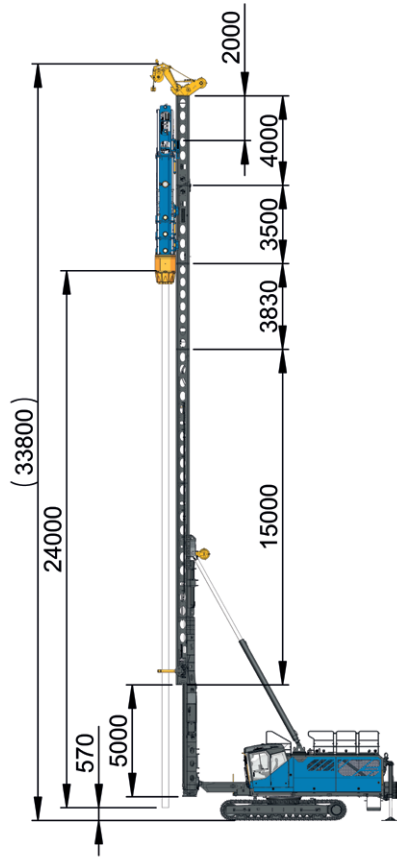

LONG

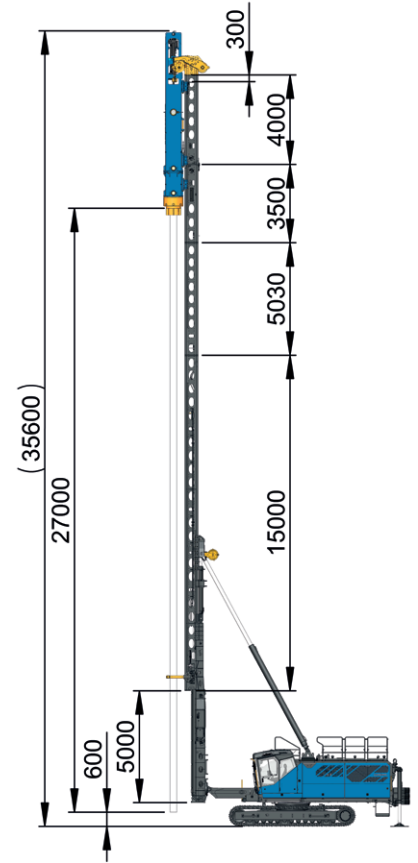

EXTENDED

MAX. PILE LENGTH	20 m (65 ft)	24 m (78 ft)	27 m (88 ft)
RECOMMENDED HAMMER	HHK/SHK5/7/9	HHK/SHK5/7/9	HHK/SHK5/7/9/10
APPROX. OPERATING WEIGHT	78 000 kg (172 000 lbs)	80 000 kg (176 000 lbs)	82 000 kg (181 000 lbs)

## Transport dimensions

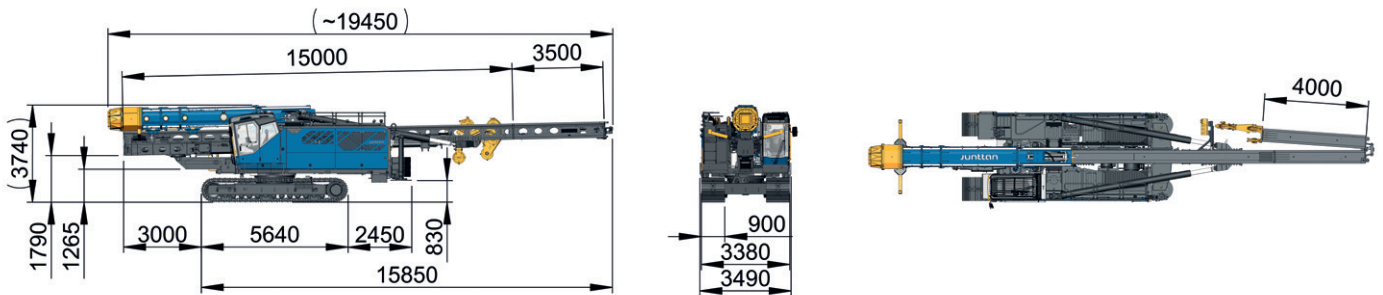

FOR FURTHER INFORMATION, PLEASE CONTACT:

Junttan Oy | [sales@junttan.com](mailto:sales@junttan.com) | [junttan.com](http://junttan.com)

# Junttan