

ELECTRIC PILE DRIVING RIGS



Junttan

Choose Junttan.

Choose Sustainable Future.

Junttan is facing the same demands as other companies in the sector for development towards a safer and more sustainable future. Our history of more than 45 years in the business has taught us much, and our products have been ahead of the competition for decades. However, there is still a lot to be done.

Over the last decade, our aim has shifted towards producing equipment with less fuel consumption, and in 2021 we launched the world's first electric pile driving rig. Our development will not stop there – plenty still needs to be done to reduce our environmental impact.



Key Features

- ✓ **Replaceable battery packs** for true 100% unplugged operation
- ✓ **Plug-in mode** for extended working time (optional feature)
- ✓ **Onboard battery** for easy battery pack change and transportation (optional feature)

Going electric does not mean compromising the efficiency and power of the machine.

When we at Junttan set out to design more sustainable innovations, we understood that a new Junttan model needed to tick all the same boxes from the very beginning as its predecessors. That's why we decided to combine the best of both worlds: tested and optimized Junttan hydraulics merged with modern batteries and electric motor technology.

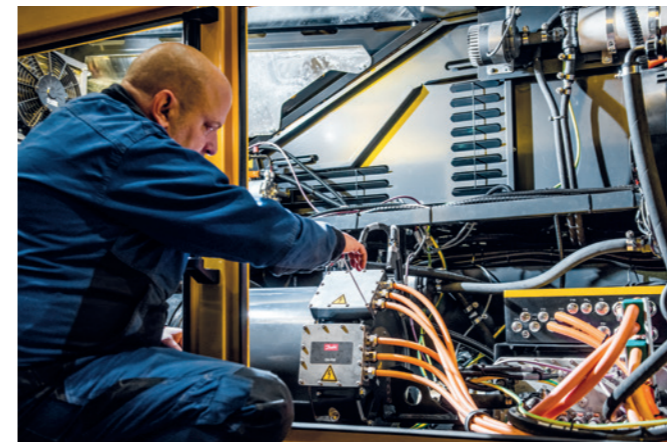

Choose industry-leading flexibility

To make everyday life at the worksite possible, we chose a solution where the rig is powered by two separate battery packs that can be replaced during the day if needed. By choosing a detachable two-battery system instead of one bigger fixed, charging can be done with a standard 63A mains outlet and both batteries are ready the next morning.

Optional features include also plug-in mode for extended working time and an onboard battery for easy battery pack change and transportation.



eJunttan

- ✓ No local CO₂ emissions
- ✓ Less consumed energy per pile
- ✓ Less noise pollution
- ✓ Up to 7 h working time with one battery pack
- ✓ More power and instant torque
- ✓ Same robust structure and usability as Junttan PMx22 and PMx24

Modern electric soul

Instead of a diesel engine, we are now powering the hydraulic system with a modern electric motor that generates its power from a battery pack at the rear of the rig where the counterweight used to be. In this way, we were able to build a solution that is reliable, easy to operate, and as effective as normal diesel-powered Junttan rigs.

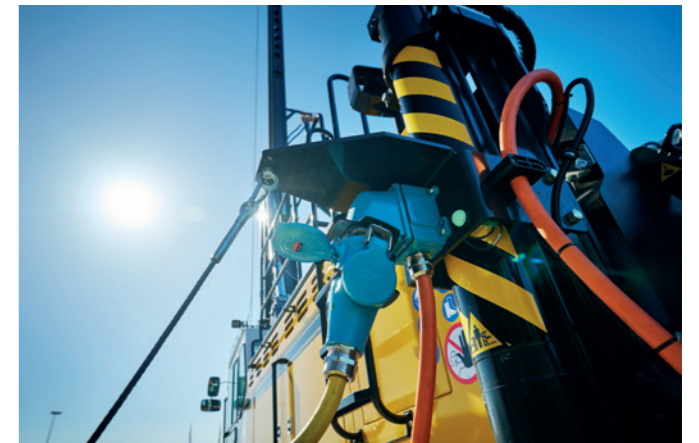

Fast charging where you need it

With the state-of-the-art CCS DC-DC quick charging the battery packs can be charged with up to 250 kW to enable even more flexibility and extended range for future worksites also with a single battery pack.

The movable charger is weatherproof and can handle dirt, water, dust, and snow. Simple charging experience – all you need is your eJunttan and electricity and you are good to go.

Technical data

MODEL	PMx2e	PMx4e
AVERAGE WORKING WEIGHT	64 000 KG (141 100 LB)	68 000 KG (149 900 LB)
LEADER CAPACITY	16 000 KG (35 300 LB)	18 000 KG (39 700 LB)
RECOMMENDED HAMMER SIZE	3-6 TONS (6 000-13 000 LB)	5-7 TONS (11 000-15 000 LB)
MAX PILE LENGTH	20 M (66 FT)	24 M (78 FT)
WINCH CAPACITY: PILE	10 000 KG (22 000 LB)	10 000 KG (22 000 LB)
WINCH CAPACITY: HAMMER	12 000 KG (26 500 LB)	12 000 KG (26 500 LB)
UNDERCARRIAGE: LENGTH	5 100 MM (200 IN)	5 100 MM (200 IN)
UNDERCARRIAGE: WIDTH (900 SHOES)	3 200-4 700 MM (126-185 IN)	3 200-4 700 MM (126-185 IN)

ELECTRIC POWER UNIT AND INVERTER

DANFOSS EM-PMI375-T1100 SERIES MOTOR, ABB HES880-SERIES INVERTER

POWER: 266 kW CONTINUOUS

TORQUE: 1 060 Nm CONTINUOUS

BATTERY PACK

	STANDARD	EXTENDED
CAPACITY	392 KWH, USABLE NET CAPACITY 352 KWH	588 KWH, USABLE NET CAPACITY 529 KWH
WORKING TIME WITH A SINGLE CHARGE *	UP TO 7 H	UP TO 10.5 H
CHARGING TIME WITH DC-BASED QUICK CHARGING WITH UP TO 250 KW POWER	1.5 H	2 H
CHARGING TIME WITH DC-BASED CHARGING UTILIZING A STANDARD 63A MAINS OUTLET	8 H	13 H
INDEPENDENT SWAPPABLE MODULE DESIGN		
INTERNAL HEATING AND COOLING CIRCUIT		
TOUCH SCREEN FOR BATTERY UNIT INFORMATION		
CCS2 CHARGING PORT FOR DC-BASED CHARGING		
EXTERNAL KEMPOWER T800 DC-CHARGING STATION		

* Medium load working cycle

OPTIONS

ON-BOARD BATTERY 33 KWH

ON-BOARD CHARGERS (40 KW) FOR CHARGING AND PLUG-IN MODE

Transport dimensions

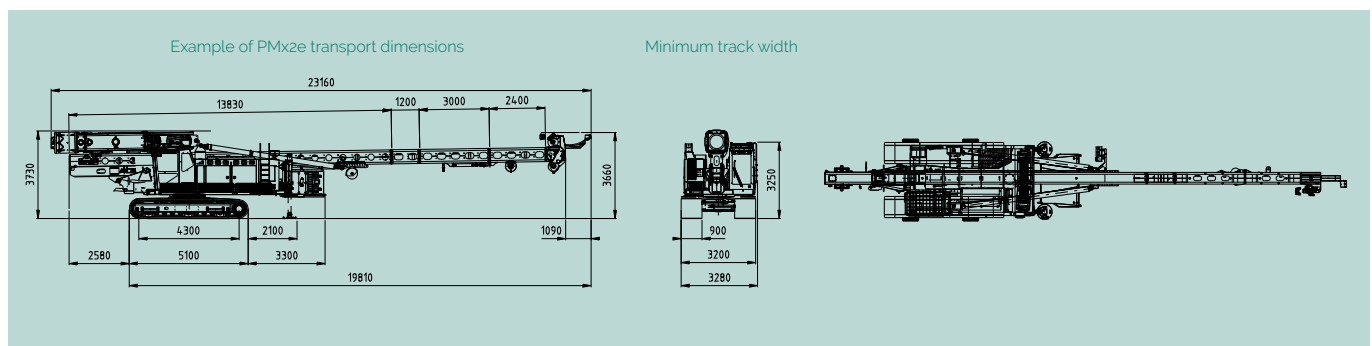

FOR FURTHER INFORMATION, PLEASE CONTACT:

sales@junttan.com | www.junttan.com

Junttan