

EVOLUTION

DR5

DRILLING RIG



Junttan

New Evolution Series

DR5

Experience the Future of Drilling

Set on a new era of piling innovation with the new Junttan Evolution series, where cutting-edge technology meets unparalleled performance. Taking the lead in this revolutionary line-up is the DR5 drilling rig, Junttan's latest innovation in drilling rig technology designed for both FDP (Full Displacement Piling) and CFA (Continuous Flight Auger) applications.

With best-in-class capacity, single-pass drilling performance, and seamless transportation and setup, this modular rig sets a new standard in efficiency and versatility. Engineered for operator comfort and equipped with top-of-the-line safety features and modern automation assistants; including a SIL-based control system, drilling, concreting, and stability assistants, the DR5 ensures optimal performance and peace of mind on every job site.



Features

- ✓ Class-leading single-pass drilling performance
- ✓ Transported as a complete, work-ready unit
- ✓ Swift and effortless rig setup via remote control
- ✓ Top-tier cabin and operator interface for unparalleled user experience

Technical data

LEADER

TYPE	DR 5	
LENGTH	LEADER SECTIONS	4 + 3 + 16,5 + 5,2 m (3.1 + 9.8 + 54.1 + 17.1 ft)
	TOTAL LENGTH	26,4-34,2 m (86.6-112.2 ft)
MAXIMUM CAPACITY	25 000 kg (55 116 lb)	
MOVEMENTS	VERTICAL	1 500 mm (59 in)
	HORIZONTAL	1 500 mm (59 in)
INCLINATIONS	ACCORDING TO SEPARATE CAPACITY TABLES	18,4° forward / 15° side / 45° backwards

JIB/ AUXILIARY WINCH

LIFTING CAPACITY	5 000 kg (11 023 lb)
TURNING RADIUS	270 °

UPPERCARRIAGE

WINCHES	SINGLE LINE PULL, 1 ST LAYER	
	MAIN WINCH 1	20 000 kg (44 092 lbs)
	MAIN WINCH 2	13 000 kg (28 660 lbs)
	3 RD WINCH	10 000 kg (22 046 lbs)
ENGINE	TYPE	
	VOLVO TAD1385VE	
	MAX POWER	405 kW (543 hp)
	FUEL TANK	800 l (211 gal)
HYDRAULIC SYSTEM	MAX FLOW	
	2 x 380 + 290 l/min (2 x 100 + 77 gal)	
	MAX PRESSURE	380 bar (5 511 psi)
	OIL TANK	780 l (206 gal)
COUNTERWEIGHT	FIXED	Max. 4 x 3000 kg (6 614 lbs)

UNDERCARRIAGE

CRAWLER LENGTH	5 660 mm (223 in)	
WIDTH (900 SHOES)	MIN.	3 380 mm (133 in)
	MAX.	4 880 mm (192 in)
TRACK SHOES	WIDTH	900 mm (35 in)

FDP application

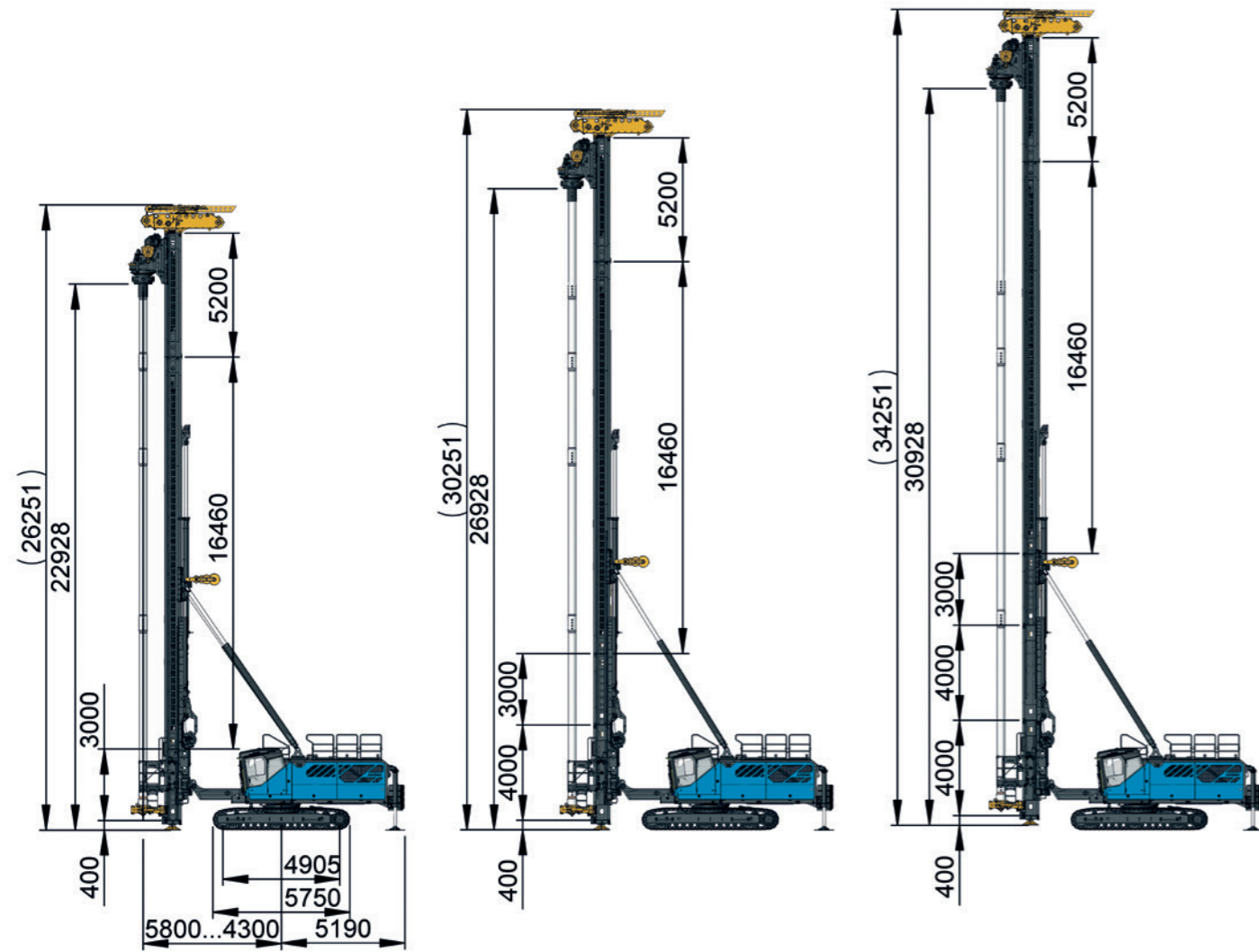

Standard

Long

Extended

	STANDARD	LONG	EXTENDED
MAX. DRILLING DEPTH	21 m (69 ft)	25 m (82 ft)	29 m (95 ft)
MAX. DRILLING DIAMETER	620 mm (24 in)	620 mm (24 in)	620 mm (24 in)
MAX. EXTRACTION FORCE	800 kN (179 847 lbf)	800 kN (179 847 lbf)	800 kN (179 847 lbf)
MAX. PULL DOWN FORCE	260 kN (58 450 lbf)	260 kN (58 450 lbf)	260 kN (58 450 lbf)
MAST EXTENSION	-	4 m (13 ft)	4 + 4 m (13 + 13 ft)
APPROX. OPERATING WEIGHT	69 000 kg (152 000 lbs)	71 000 kg (157 000 lbs)	74 000 kg (163 000 lbs)

CFA application

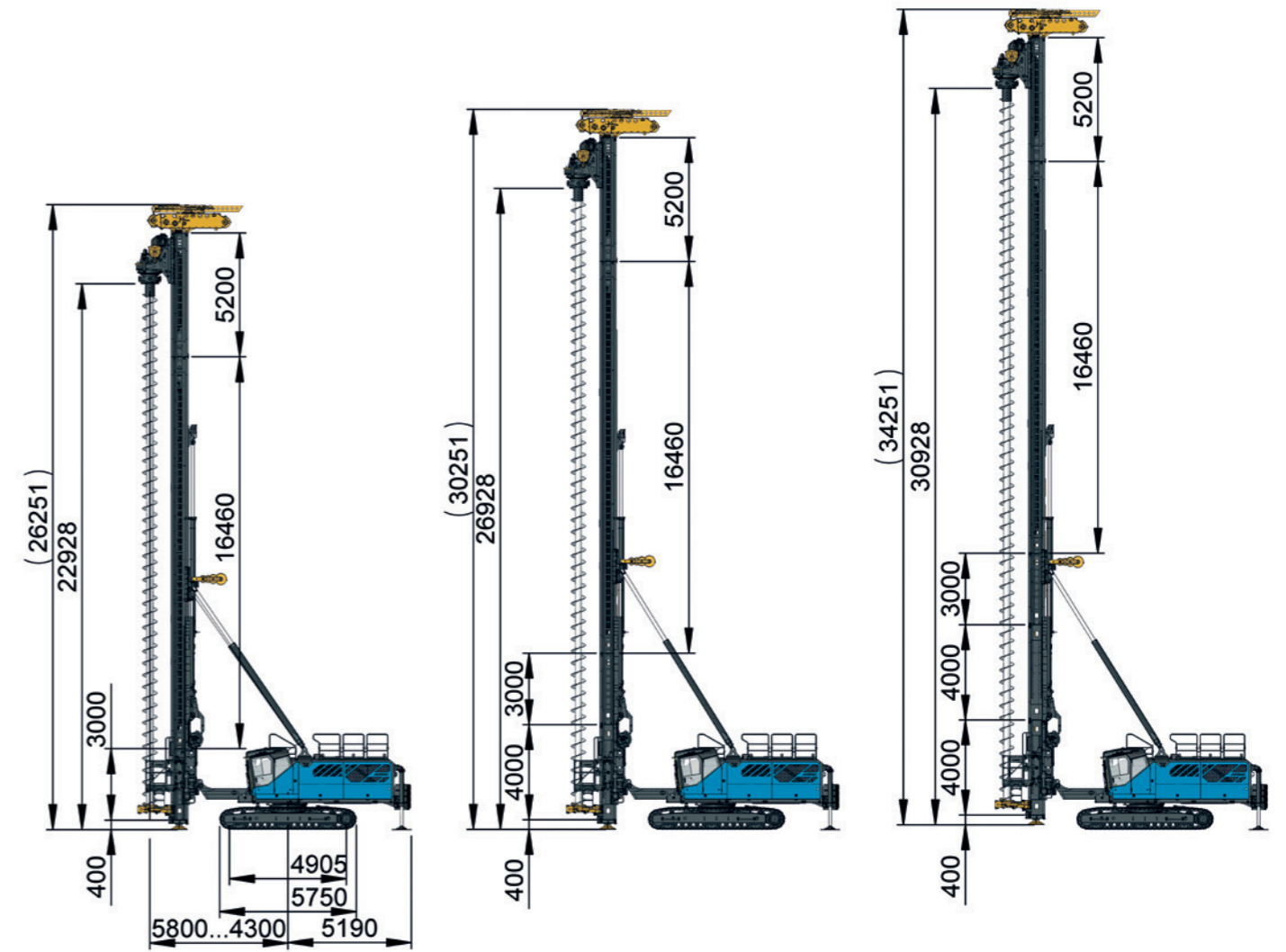

Standard

Long

Extended

	STANDARD	LONG	EXTENDED
MAX. DRILLING DEPTH	21 m / 20 m* (69 / 66* ft)	25 m / 24 m* (82 / 79* ft)	29 m / 28 m* (95 / 92 ft)
MAX. DRILLING DIAMETER	1 200 mm (47 in)	1 200 mm (47 in)	1 200 mm (47 in)
MAX. EXTRACTION FORCE	800 kN (179 847 lbf)	800 kN (179 847 lbf)	800 kN (179 847 lbf)
MAX. PULL DOWN FORCE	260 kN (58 450 lbf)	260 kN (58 450 lbf)	260 kN (58 450 lbf)
MAST EXTENSION	-	4 m (13 ft)	4 + 4 m (13 + 13 ft)
APPROX. OPERATING WEIGHT	69 000 kg (152 000 lbs)	71 000 kg (157 000 lbs)	74 000 kg (163 000 lbs)

* With Auger Cleaner

RH30 Rotary head



TECHNICAL DATA

WEIGHT (BASIC ROTARY HEAD INCL. SLEDGE)	3 500 kg (7 716 lbs)
WEIGHT (INCL. SLEDGE, TOOL ADAPTER, CROSS JOINT AND CONCRETING EQUIPMENT)	4 900 kg (10 803 lbs)
HEIGHT	2 660 mm (105 in)
WIDTH	2 030 mm (80 in)
LENGTH	1 670 mm (66 in)

PERFORMANCE	GEAR 1	GEAR 2	OPTIONAL GEAR 3
TORQUE(MAX)	300 kNm @ 6 rpm (221 269 ft-lb @ 6 rpm)	175 kNm @ 16 rpm (129 073 ft-lb @ 16 rpm)	50 kNm @ 57 rpm (36 878 ft-lb @ 57 rpm)
SPEED(MAX)	30 rpm @ 100 kNm (30 rpm @ 73 756 ft-lb)	56 rpm @ 50 kNm (56 rpm @ 36 878 ft-lb)	88 rpm @ 32 kNm (88 rpm @ 23 602 ft-lb)

Transport dimensions

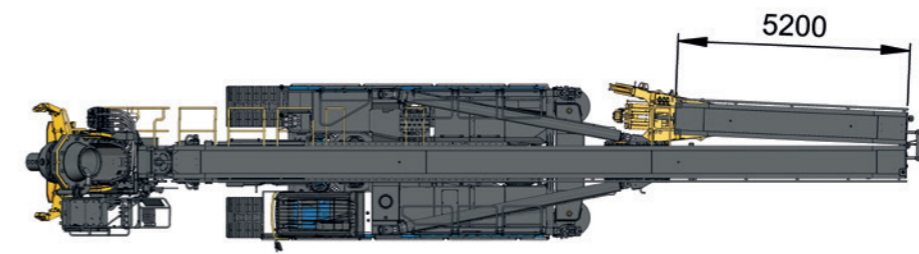
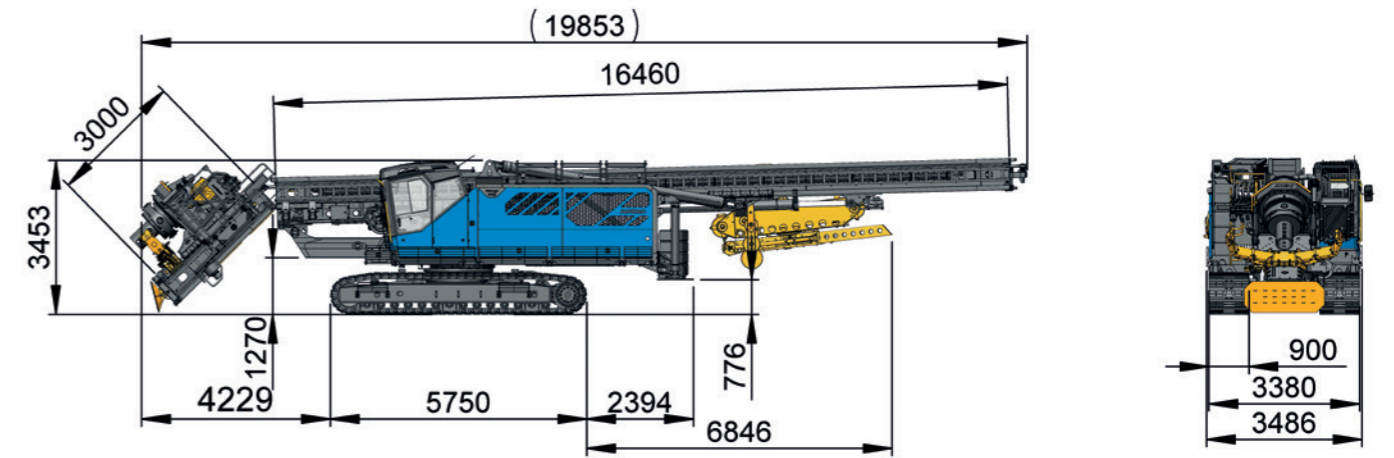

DR5 & RH30 Torque vs. Speed

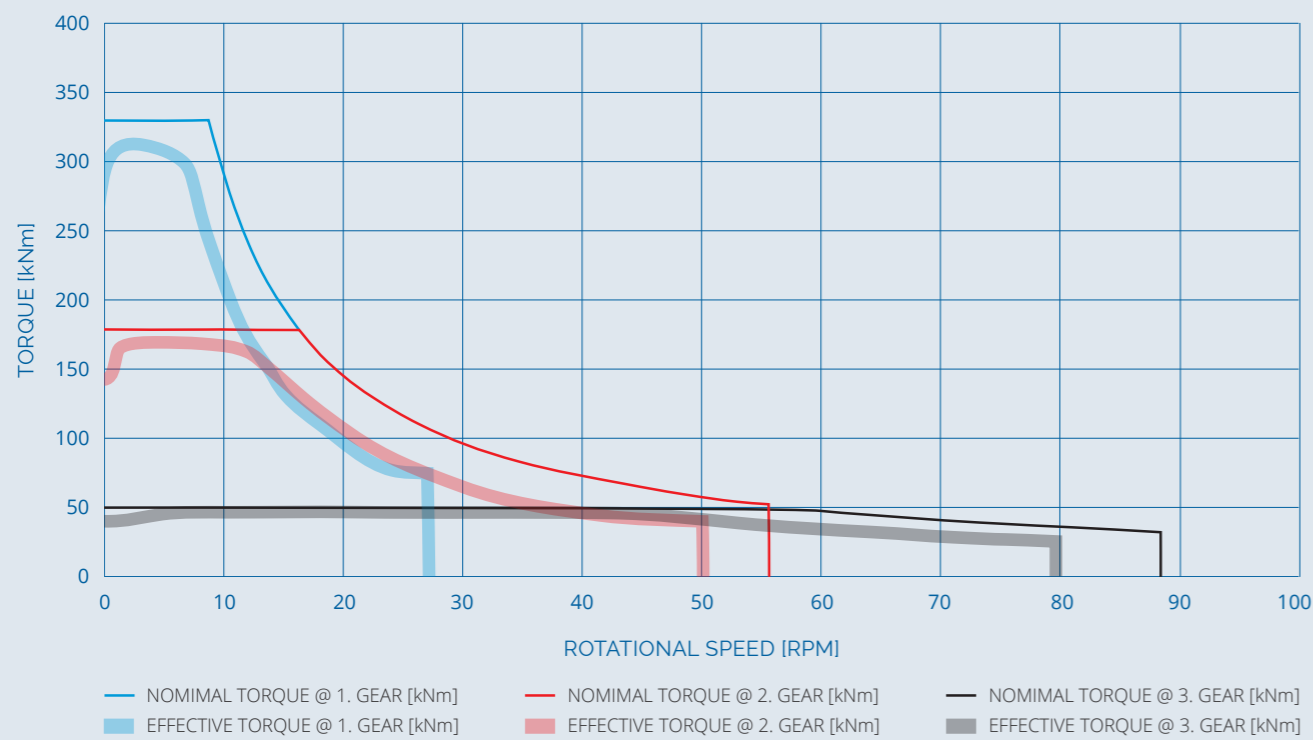

* RH30 image shows configuration optimized for open concreting system FDP piles.

At your service

Combining state-of-the-art piling machinery with uncontested customer service and sheer determination to do everything there is to do to help customers succeed, Junttan can improve also your operational efficiency.

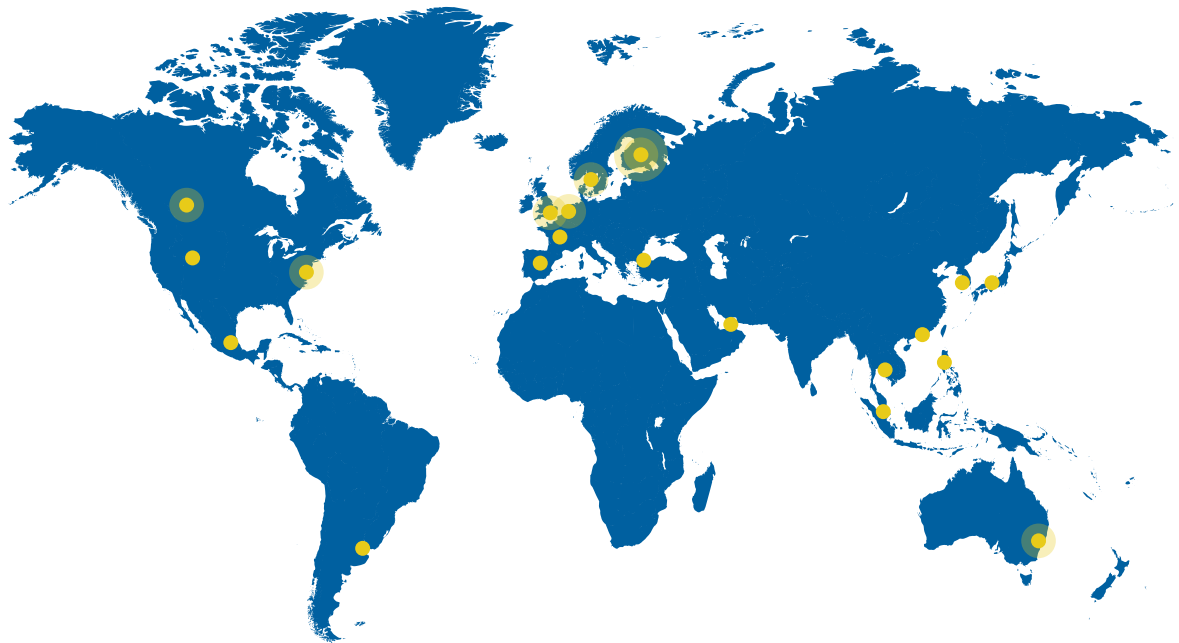

FIND YOUR NEAREST JUNTAN PROFESSIONAL HERE:
junttan.com/contact-us

FOR FURTHER INFORMATION, PLEASE CONTACT:
Junttan Oy | sales@junttan.com | junttan.com

Junttan