

VH120

Free-hanging Vibratory Hammer

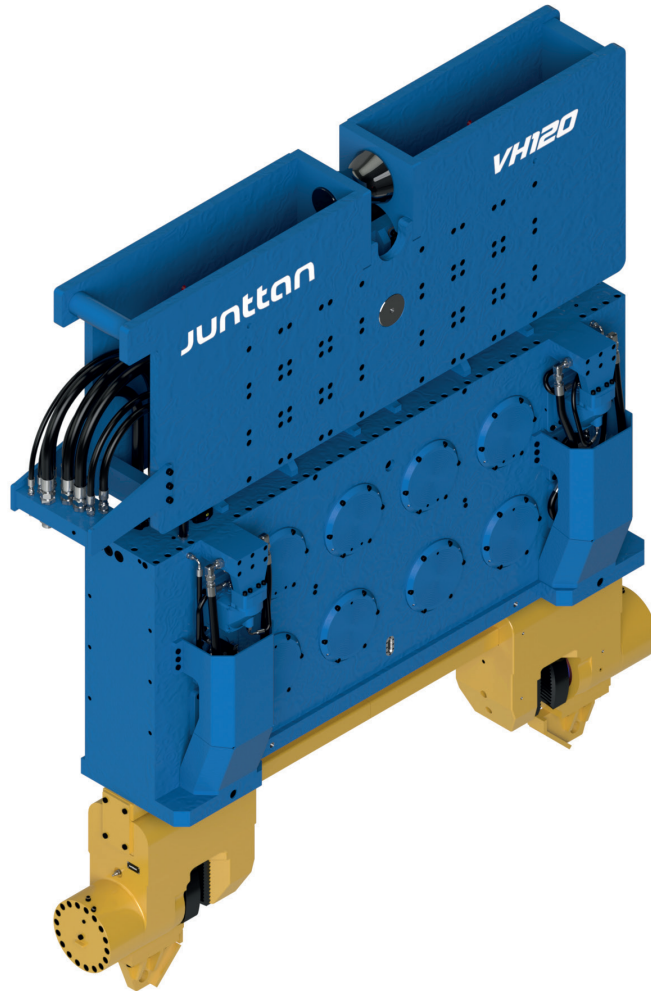

When a high driving
or extracting force
is needed.

The Junttan normal frequency Vibratory Hammers (VH), is your go to solution for projects that demand exceptional force for driving or extracting. Unlocking the true power of innovation, Junttan presents a range of free-hanging vibratory hammers powered by the Junttan vibratory Power Pack series (PP series).

Key features

- ✓ Soil conditions from moderate to difficult driving conditions
- ✓ For driving and extracting tubular, sheet and H-piles
- ✓ Robust, proven design
- ✓ Easy handling of different clamping solutions

Technical data

Technical Specifications

UNIT	METRIC	US
ECCENTRIC MOMENT	120 KGM	10416 IN.LBS
CENTRIFUGAL FORCE MAX.	2846 KN	320 TONS
FREQUENCY	1480 RPM	1480 RPM
OIL FLOW	1122 L/MIN	297 GPM
POWER	655 KW	878 HP
AMPLITUDE	26 MM	1 IN
PULLING FORCE MAX.	1059 KN	119 TONS

Weight and Dimensions

UNIT	METRIC	US
DYNAMIC WEIGHT W/O CLAMP	9145 KG	20162 LBS
TOTAL WEIGHT W/O CLAMP	12172 KG	26835 LBS
LENGTH / L1	3315 MM	131 IN
LENGTH / L2	3070 MM	121 IN
LENGTH / L3	3390 MM	133 IN
HEIGHT / H1	2682 MM	106 IN
HEIGHT / H2	3786 MM	149 IN
WIDTH / W1	455 MM	18 IN
WIDTH / W2	728 MM	29 IN
WIDTH / W3	370 MM	15 IN
THROAT WIDTH	430 MM	16.9 IN

Recommended Clamp Type for Sheet Piles / SC 350

UNIT	METRIC	US
CLAMPING FORCE	3560 KN	400 TONS
WEIGHT	2553 KG	5629 LBS

Recommended Clamp Type for Casing / TC185 x 2 / 4

UNIT	METRIC	US
DIAMETER (MIN. - MAX.) / D	520-2000 / 1000-3000 MM	21-83 / 40-118 IN
CLAMPING FORCE	1858 X 2 / 1858 X 4 KN	418 / 836 TONS
WEIGHT	1164 X 2 / 1164 X 4 KG	5133 / 10264 LBS

Recommended Power Pack / PP1400

UNIT	METRIC	US
OIL FLOW MAX.	1460 LPM	385 GPM
PRESSURE MAX.	350 BAR	5076 PSI
OIL CAPACITY	2800 LITER	739 GAL
DIESEL TANK CAPACITY	1000 LITER	264 GAL
WIDTH	2445 MM	96 IN
LENGTH	6060 MM	239 IN
HEIGHT	2590 MM	102 IN
WEIGHT	13100 KG	28880 LBS

STAGE	MODEL	POWER
Stage V / Tier 4F	2 X VOLVO TAD1385VE	810 / 1102 KW/HP

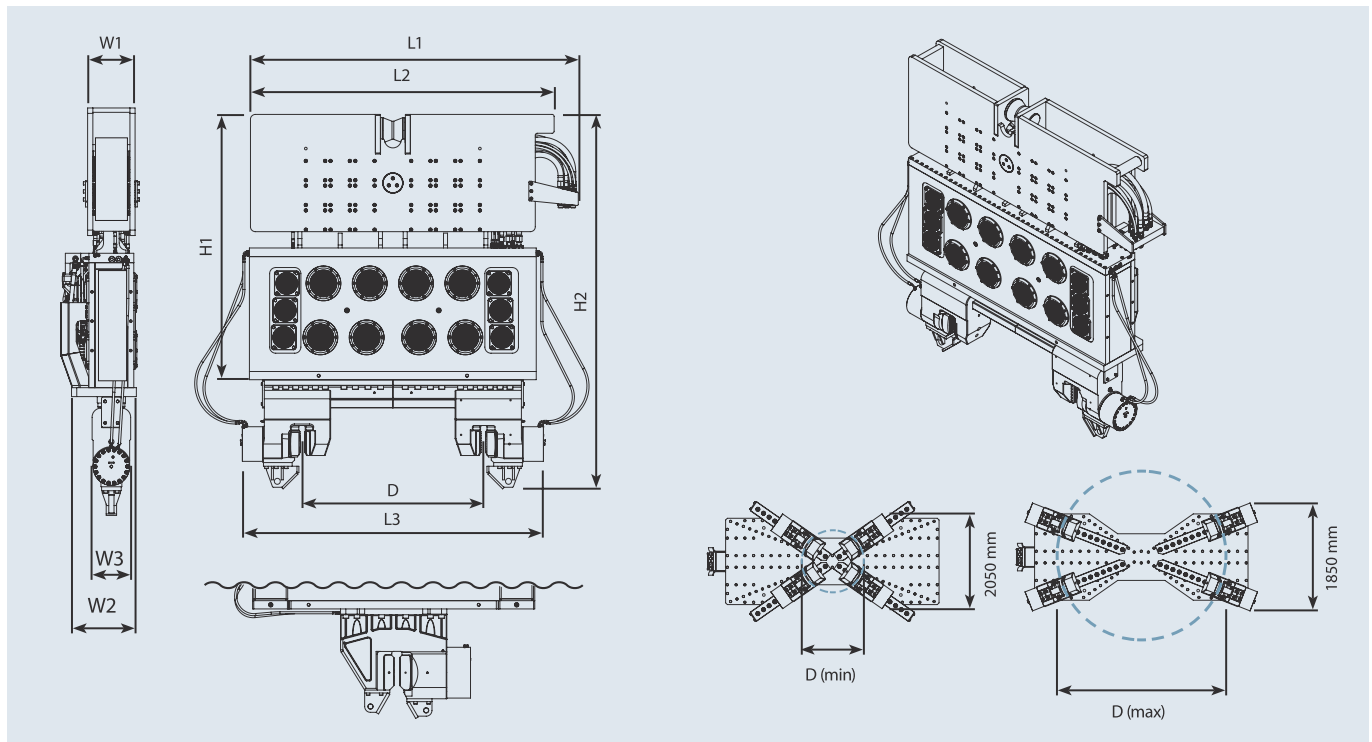

FOR FURTHER INFORMATION, PLEASE CONTACT:

Junttan Oy, sales@junttan.com, www.junttan.com

Junttan