

## PP700

### Hydraulic power packs

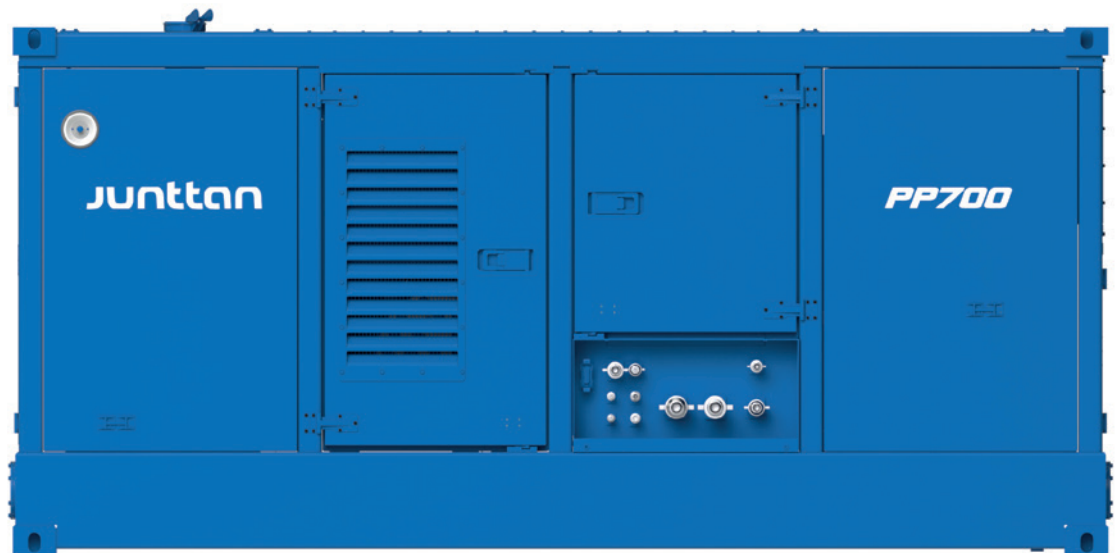

Junttan power units can be controlled via the main control panel and instant information in relation to the hydraulic system, engine and retrospective failure logging can be obtained.

Junttan Power Packs predict possible failures and have advanced fault detection technology to enable self-reprogramming. Intelligent control system prevents use until the system reaches the optimum working conditions. These features ensure a long life for all components. Junttan power units are available with closed or open loop hydraulic systems. Auxiliary systems are fed by one variable flow pump. The make of engine is optional.

#### Key features

- ✓ Simple and user-friendly touch screen control panel
- ✓ Advanced diagnostic features
- ✓ Robust and reliable design using proven components
- ✓ Intelligent features like automatic heating cycle for hydraulic oils
- ✓ Easy to handle and transport with optimized lifting and stacking features

# Technical specifications

## PP700

UNIT	METRIC	US	STAGE	MODEL	POWER
OIL FLOW MAX.	729 (LPM)	192 (GPM)	Tier 3	VOLVO TAD1352VE	315 / 428 (KW/HP)
PRESSURE MAX.	350 (BAR)	5076 (PSI)	Stage V / Tier 4F	VOLVO TAD1385VE	405 / 551 (KW/HP)
OIL CAPACITY (Tier 3)	650 (LITER)	171 (GAL)			
OIL CAPACITY (Stage V / Tier 4F)	750 (LITER)	198 (GAL)			
DIESEL TANK CAPACITY	800 (LITER)	211 (GAL)			
WIDTH	1820 (MM)	71 (IN)			
LENGTH	4520 (MM)	178 (IN)			
HEIGHT	2175 (MM)	86 (IN)			
WEIGHT (Tier 3)	7600 (KG)	16755 (LBS)			
WEIGHT (Stage V / Tier 4F)	8100 (KG)	17857 (LBS)			

\* Technical specifications are calculated with respect to maximum pressure and oil flow. Both pressure and oil flow can be adjusted depending on the needs.

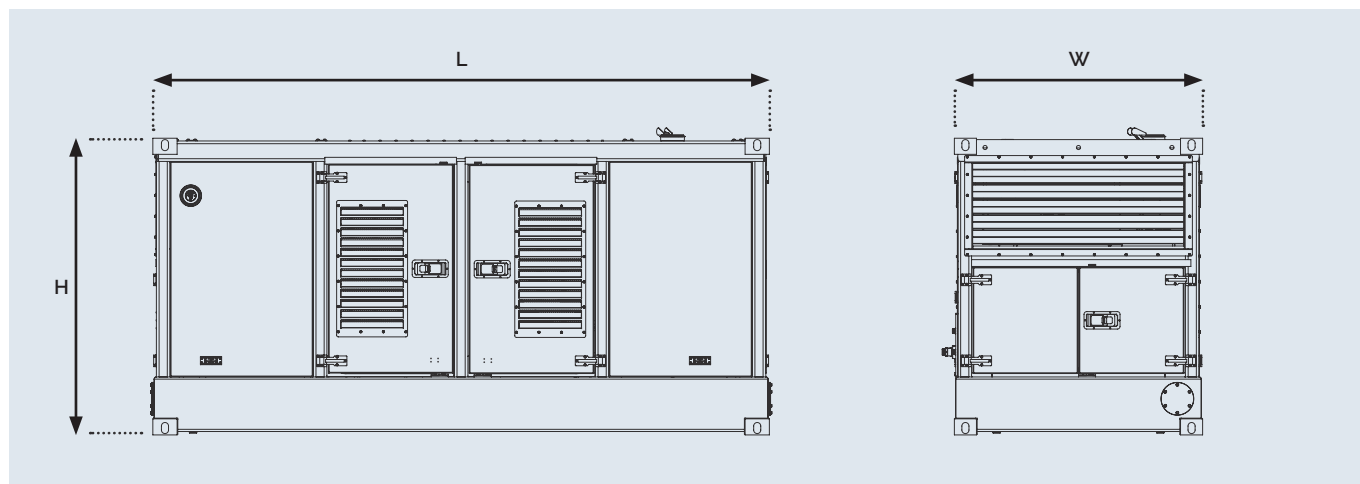

## Control panel

### Remote Control

THE VIBRATOR CAN BE FULLY CONTROLLED BY THE REMOTE CONTROL

- Engine speed adjustment
- Amplitude/moment adjustment
- Clamp pressure safety lamp
- Vibrator start/stop switch
- Clamp open/close switch
- Clamp open safety switch
- Emergency stop button



FOR FURTHER INFORMATION, PLEASE CONTACT:

Junttan Oy, sales@junttan.com, www.junttan.com

**Junttan**