

Multipurpose Piling Rig

PM 28

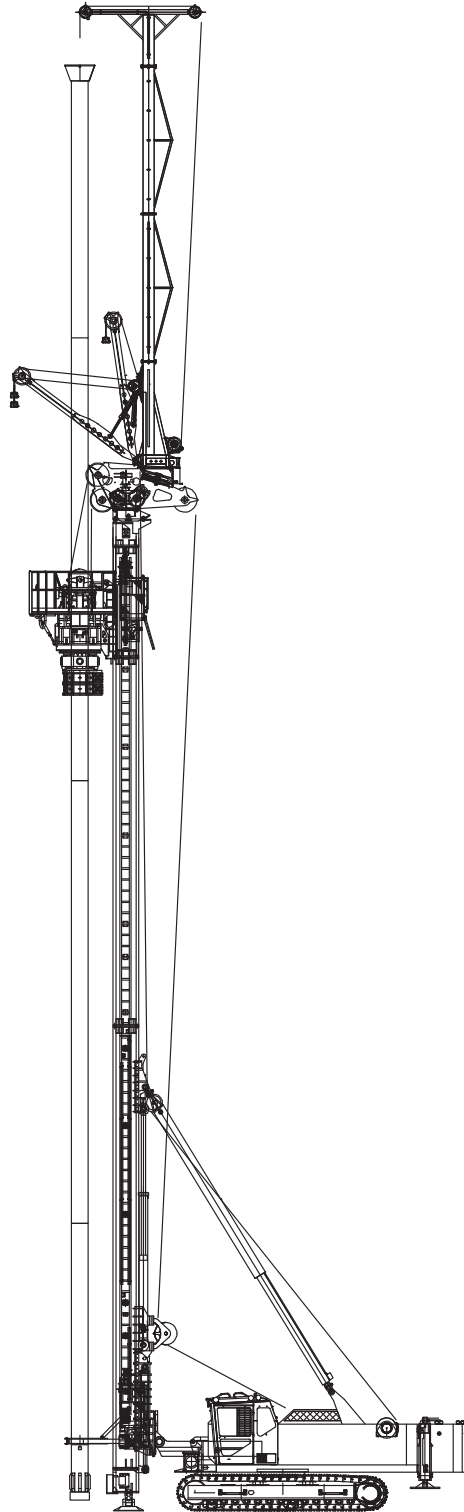

General Information

Junttan PM 28 is a multipurpose piling rig for heavy-duty working. The rig can be equipped with Displacement, driven cast-in-situ, CFA or large diameter piling equipment as well as driven methods. The maximum drilling torque is 400 kNm. The rig has a proven productivity due to top piling performance with Junttan rotary heads. With optional Junttan equipment, optimised working set-up of the rig can be easily achieved.

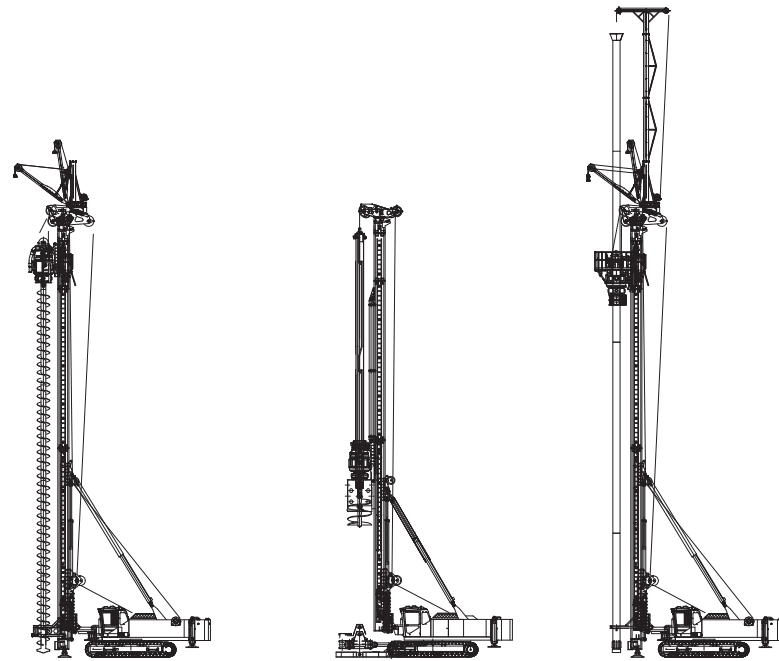

Multipurpose Piling Rigs

Model PM 28	CFA	Kelly	Displacement
Average working weight	100 000 kg (220 500 lb)	100 000 kg (220 500 lb)	100 000 kg (220 500 lb)
Leader capacity	30 000 kg (66 100 lb)	30 000 kg (66 100 lb)	30 000 kg (66 100 lb)
Recommended Ram weight			
Max. pile length	26 m (85 ft)	70 m (230 ft)	32 m (105 ft)
Max. Working tube length		6 m (casing) (20 ft)	35 m (115 ft)
Max. Pile diameter	1 200 mm (47 in)	2 000 mm (79 in)	810 mm (32 in)
Max.torque	400 kNm	400 kNm	400 kNm
Engine power	388 kw (520 hp)	388 kw (520 hp)	388 kw (520 hp)
Winch capacity: Main	25 ton (55 100 lb)	25 ton (55 100 lb)	25 ton (55 100 lb)
Max.extraction	100 ton (220 500 lb)	100 ton (220 500 lb)	100 ton (220 500 lb)
Winch capacity: Aux. 1	12 ton (26 500 lb)	12 ton (26 500 lb)	12 ton (26 500 lb)
Max pull down	36 ton (79 500 lb)	36 ton (79 500 lb)	36 ton (79 500 lb)
Undercarriage: Length	5 700 mm (225 in)	5 700 mm (225 in)	5 700 mm (225 in)
Undercarriage: Width (900 shoes)	3 500 - 4 770 mm (138 - 188 in)	3 500 - 4 770 mm (138 - 188 in)	3 500 - 4 770 mm (138 - 188 in)

Technical Data

Basic features

Nominal operational weight (drilling)		100 000 kg	220 500 lb
Leader capacity		30 000 kg	66 100 lb
Winch capacity	Pile:	12 000 kg	26 500 lb
	Hammer:	25 000 kg	55 100 lb
	Auxiliary:	5 000 kg	11 000 lb
Recommended rotary type		JD40	JD40
Recommended hammer type		SHK 110-5 - HHK 12	SHK 110-5 - HHK 12
	Maximum pile length (SHK 110-7)	25 m	82 ft

Uppercarriage

Type		Junttan PM28	
Engine	Type:	Cummins QSX15	
	Power:	388 kW	520 hp
	Fuel tank:	850 liters	224 gal
Hydraulic system	Max flow:	2x400 + 180 lpm/2 000rpm	2x42 + 24 gpm/2 000rpm
	Max pressure:	350 bar	4 640 psi
	Cooling system:	3xT7 coolers	
	Oil tank:	1 100 liters	290 gal
Slew drive	Double drive, 1 600 mm single row slewing ring		
Counterweight	Extendable:	4-6x2 000 kg	4-6x4 400 lb
	Additional	2x1 000 kg (in rear legs)	2x2 200 lb

Leader

Type		Fixed PM28	
Movements	Foot (up/down)	1 000/100 mm	40/4 in
	Horizontal	900 mm	35½ in
Inclinations	According separate capacity tables		
	Electronic inclinometer included		

Undercarriage

Type		JV57160MP	
Crawler length		5 700 mm	225 in
Crawler type		D7E	D7E
Width (900 shoes)	Min:	3 492 mm	138 in
	Max:	4 770 mm	188 in
Track shoe options	Width:	800/900/1 000 mm	31½/35½/39½ in
	Surface:	3-edge / flat edges / flat	
	Edge type:	normal / chamfer / bended	

Accessories

* Side cathead		* iPiler PCD
* Side auger	JD3	* Air conditioning
* Rear support legs		* Auxiliary winch (5 000kg / 11 000 lb)
* Multipurpose options		

* Contact Junttan sales for all available options and accessories

Transport Dimension

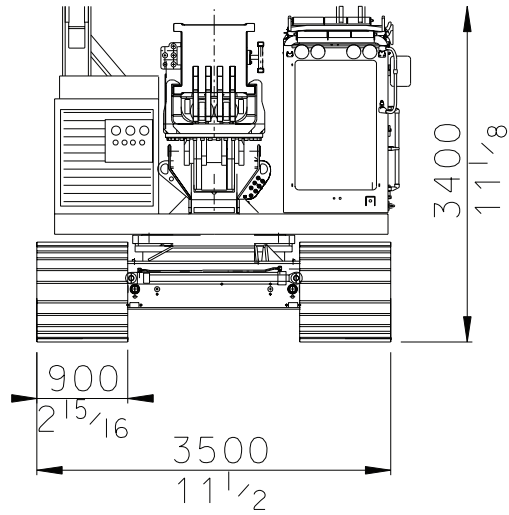

Minimum track width.

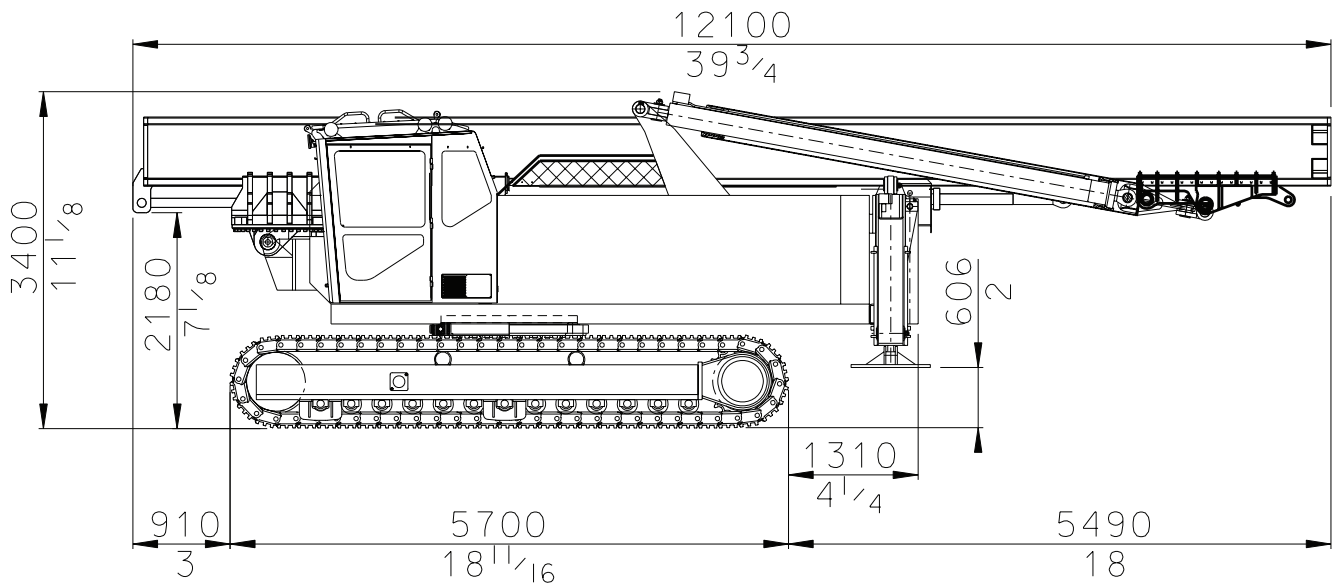

PM 28 transport dimensions.

Junttan

Junttan Oy
P.O. Box 1702 (Matkuksentie 7)
FI-70701 KUOPIO, Finland

Tel. +358 10 195 221
Fax +358 17 287 4411
junttan@junttan.com