

Junttan

Pile Driving Rig

PM25H

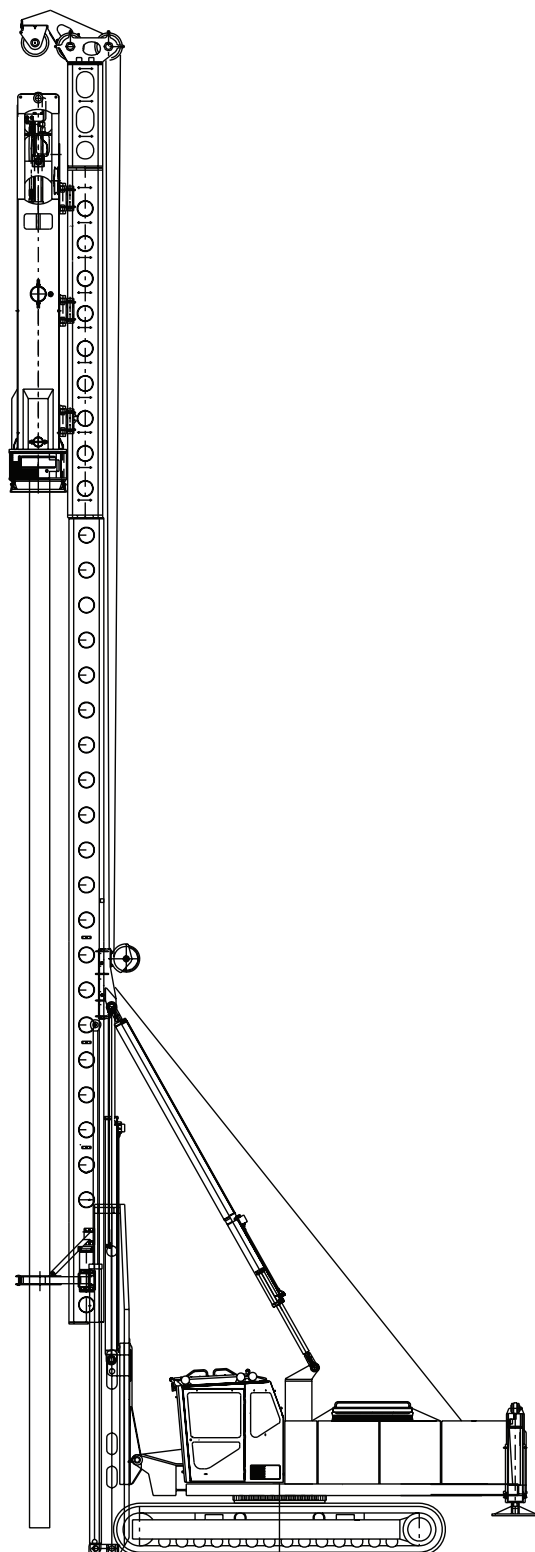

Original
Junttan
product

DATA SHEET

General Information

Junttan PM25H is a medium weight piling rig designed for driving steel and concrete piles. PM25H is Junttan's biggest pile driving rig with telescopic leader for extremely efficient and more powerful for heavy duty use. The rig has excellent stability and wide leader inclination angles. The recommended ram hammer weight is from 5 000 to 9 000 kg and the maximum pile length is 25 meters (82 ft). The rig has proven productivity. The telescopic leader ensures easy and fast handling of piles. Top pile driving performance is guaranteed with Junttan hydraulic hammers. An optional side drill or vibrator hammer makes pile driving even more efficient in some soil conditions. With optional Junttan equipment, optimised working set-up of the rig can be easily achieved.

This Junttan piling rig has the all proven Junttan features. Its rugged design makes it a safe and reliable rig even in the most demanding working conditions. The self-erecting leader and many advanced technical features ensure that the rig is ready to work in just a few minutes. The ergonomic and safety tested cabin allows the driver to concentrate completely on his work. The expandable tracks and low centre of gravity make the rig exceptionally stable in different working situations. The horizontal movement of the leader ensures fast spotting of the pile. In spite of larger size the rig can be still easily transported to a new working site.

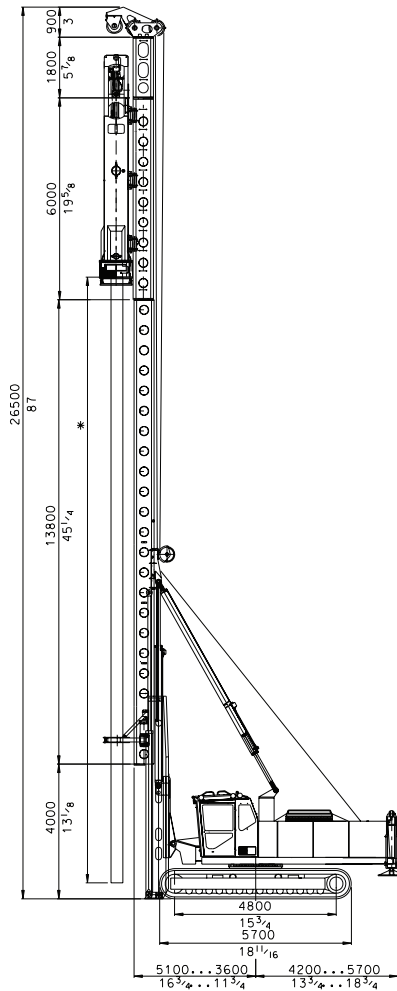

Standard PM25H with HHK 7A hammer for pile driving

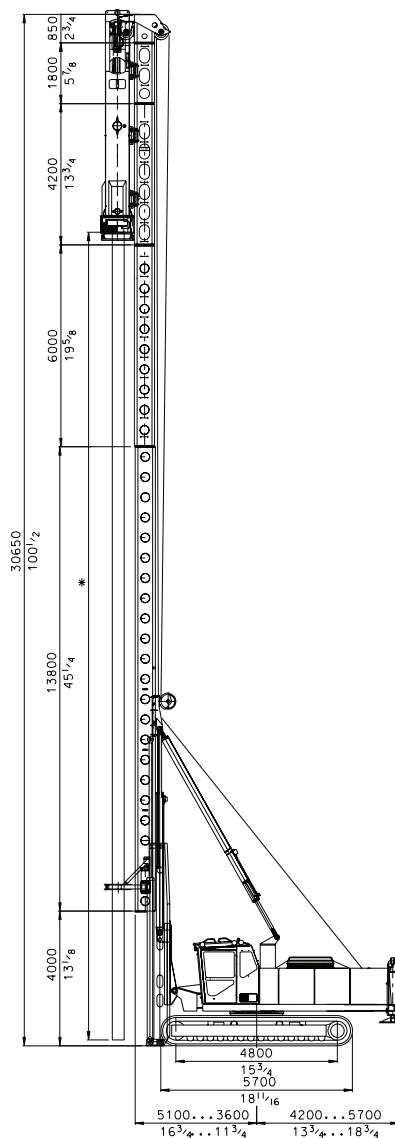

PM25H with longest available leader configuration and HHK 7A hammer for pile driving

* Pile length depends on the hammer.

Technical Data

Basic features

Nominal operational weight		78 000 kg	172 000 lb
Leader capacity		20 000 kg	44 000 lb
Winch capacity	Pile:	10 000 kg	22 000 lb
	Hammer:	15 000 kg	33 100 lb
	Auxiliary:	5 000 kg	11 000 lb
Recommended hammer type		SHK 110-5 – SHK 110-9	SHK 110-5 – SHK 110-9
Maximum pile length (SHK 110-5)		25 m	82 ft

Uppercarriage

Type		Junttan PM25H	
Engine	Type:	Cummins QSM11	
	Power:	280 kW	376 hp
	Fuel tank:	420 liters	110 gal
Hydraulic system	Max flow:	2x280 + 120 lpm/2000rpm	2x42 + 24 gpm/2 000rpm
	Max pressure:	320 bar	4 640 psi
	Cooling system:	2xT8 coolers	
	Oil tank:	670 liters	177 gal
Slew drive		Single drive, 1600mm single row slewing ring	
Counterweight	Extendable:	6 000 + 2 000 kg	13 230 + 4 400 lb

Leader

Type		Telescopic PM25H	
Movements	Telescope	4 000 mm	158 in
	Foot (up/down)	1 000/500 mm	40/20 in
	Horizontal	1 500 mm	59 in
Inclinations	According separate capacity tables Electronic inclinometer included		

Undercarriage

Type		JH57160	
Crawler length		5 700 mm	225 in
Crawler type		D7A	
Width (900 shoes)	Min:	3 380 mm	133 in
	Max:	4 880 mm	192 in
Track shoe options	Width:	800/900/1 000 mm	31½/35½/39½ in
	Surface:	3-edge / flat edges / flat	
	Edge type:	normal / chamfer / bended	

Accessories

* Side cathead			* iPiler PCD
* Side auger	JD3		* Air conditioning
* Rear support legs			* Auxiliary winch (5 000kg / 11 000 lb)

* Contact Junttan sales for all available options and accessories

Transport Dimension

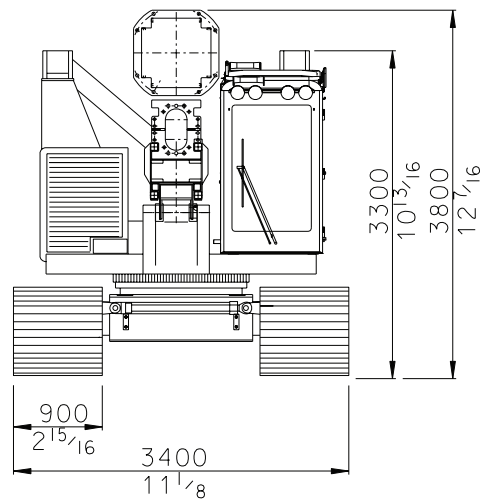

Minimum track width.

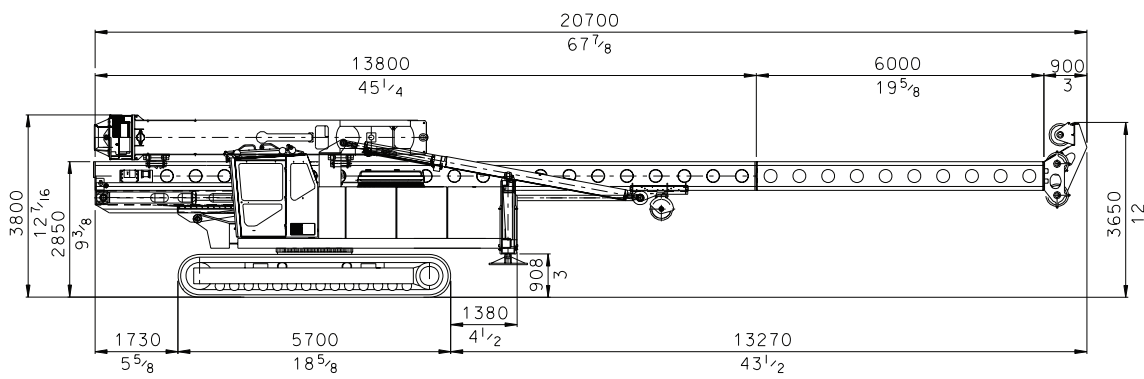

Standard PM25H transport dimensions with HHK 7A hammer.

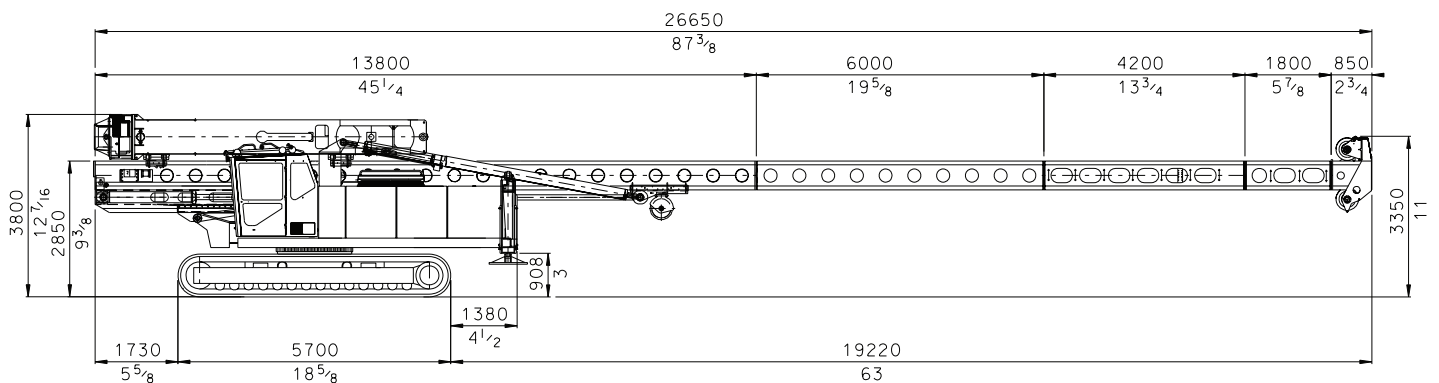

PM25H transport dimensions with longest available leader configuration, HHK 7A hammer and side cathead.

Junttan

Junttan Oy
P.O. Box 1702 (Matkuksentie 7)
FI-70701 KUOPIO, Finland

Tel. +358 10 195 221
Fax +358 17 287 4411
junttan@junttan.com