

Junttan

Pile Driving Rig

PM23

(long reach boom)

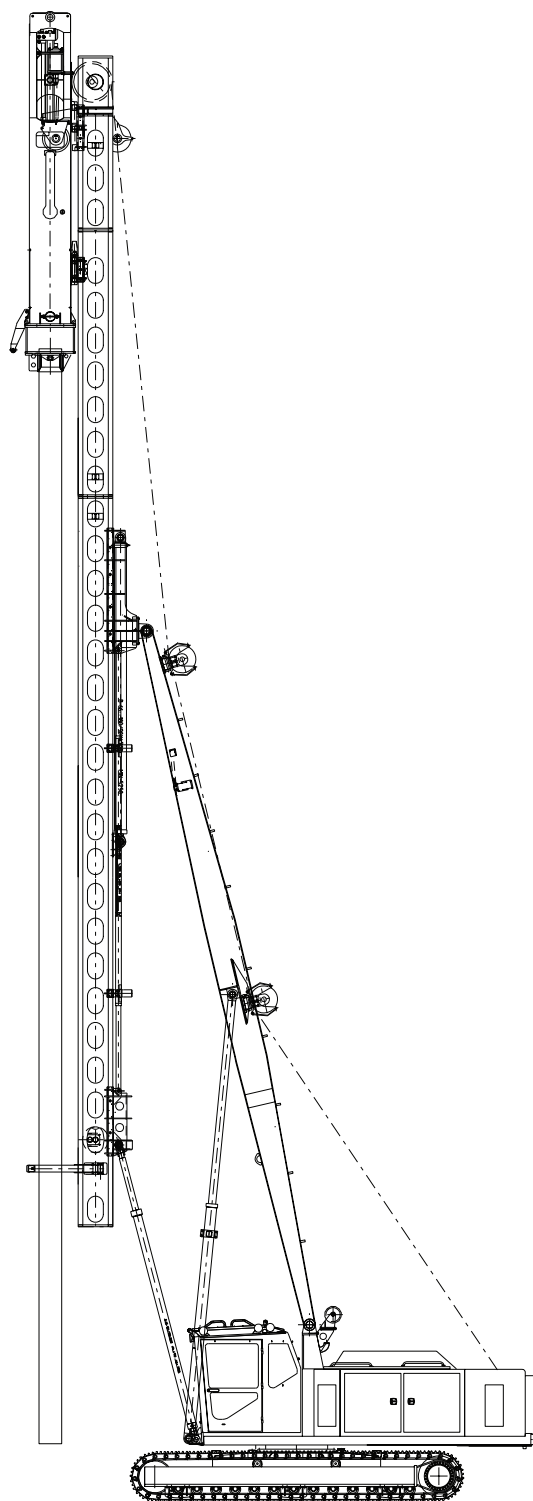

Original
Junttan
product

DATA SHEET

General Information

Junttan PM23 is a special piling rig designed for job sites where a long leader reach is needed. It's ingenious boom and leader structure enables great inclinations in all directions. It is an ideal rig for e.g. bridge, port and railroad worksites. The rig can be used for driving timber, concrete and different types of steel piles. The recommended hammer ram weight is from 3 000 to 5 000 kg and maximum pile length is 20 meters (66 ft). Because of the long reach of the leader, piles can be handled fast and easily ensuring high productivity. Top pile driving performance is guaranteed with Junttan hydraulic hammers. An optional side drill or vibrator hammer makes pile driving even more efficient in some soil conditions. With optional Junttan equipment, optimised working set-up of the rig can be easily achieved.

This Junttan piling rig has the same proven features as the bigger Junttan machines. Its rugged design makes it a safe and reliable rig even in the most demanding working conditions. The selferecting leader and many advanced technical features ensure that the rig is ready to work in just a few minutes. The ergonomic and safety tested cabin allows the driver to concentrate completely on his work. The expandable tracks and low centre of gravity make the rig exceptionally stable in different working situations. The long reach of the leader ensures fast spotting of the pile and allows piling in even the most demanding places. Because of compact size the rig can be easily transported to a new working site.

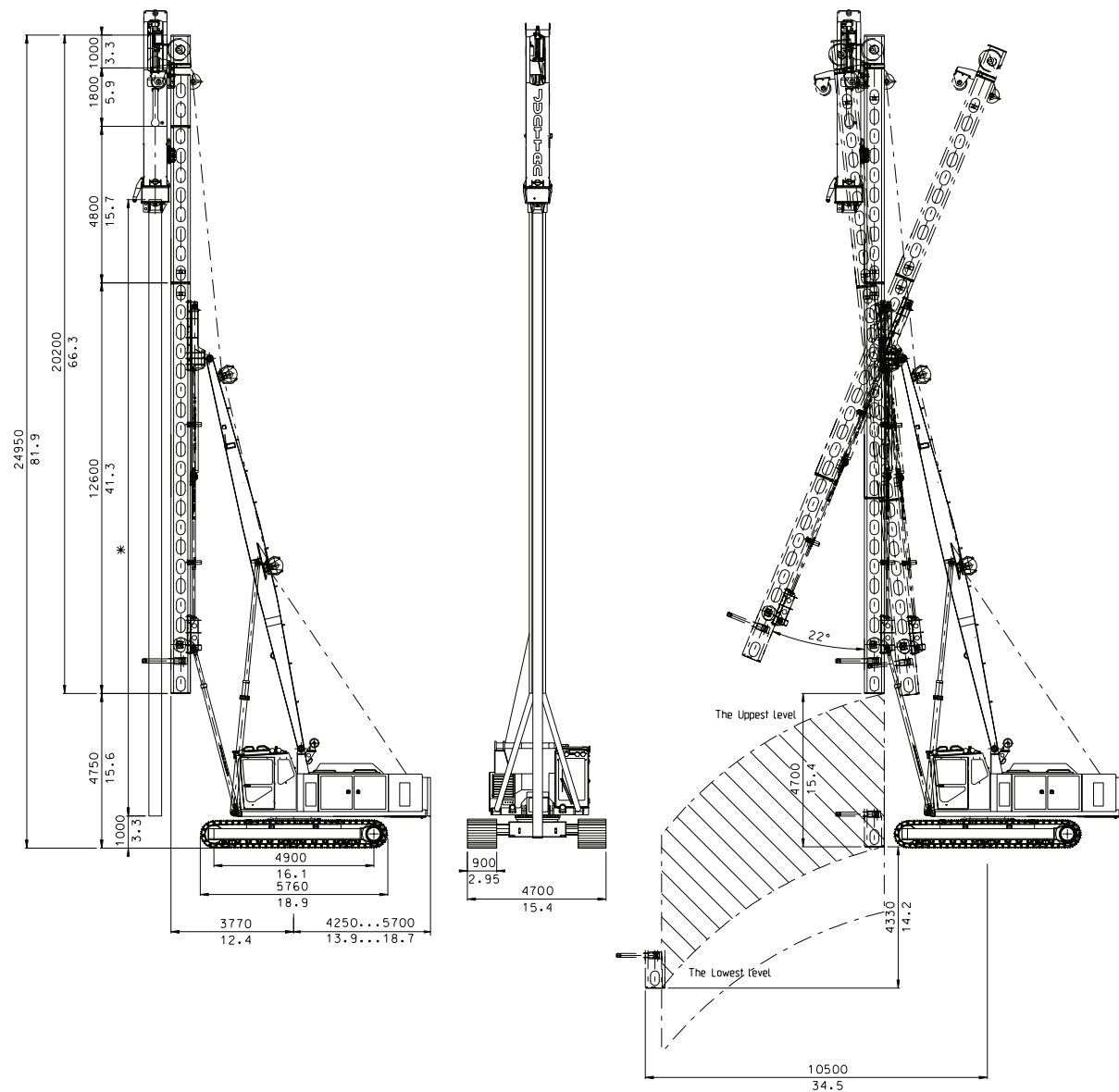

* Pile length depends on the hammer.

Technical Data

Basic features

Nominal operational weight		65 000 kg	143 300 lb
Leader capacity		14 000 kg	30 900 lb
Winch capacity	Pile:	8 000 kg	17 600 lb
	Hammer:	10 000 kg	22 000 lb
	Auxiliary:	N/A	N/A
Recommended hammer type		HHK 3 – HHK 5A	HHK 3 – HHK 5A
Maximum pile length (HHK 3A)		20 m	66 ft

Uppercarriage

Type		Junttan PM23	
Engine	Type:	Cummins QSB6,7	
	Power:	179 kW	240 hp
	Fuel tank:	600 liters	158 gal
Hydraulic system	Max flow:	2x214 + 120 lpm/2000rpm	2x57 + 32 gpm/2 000rpm
	Max pressure:	320 bar	4 640 psi
	Cooling system:	2xT6 coolers	2xT6 coolers
	Oil tank:	600 liters	158 gal
Counterweight	Extendable:	6 000 kg	13 230 lb

Leader

Type		Long reach PM23	
Movements	Vertical (up/down)	4 700/4 330 mm	185/170 in
	Horizontal	6 650 mm	262 in
Inclinations	According separate capacity tables Electronic inclinometer included		

Undercarriage

Type		JH57138	
Crawler length		5 700 mm	225 in
Crawler type		D57	
Width (900 shoes)	Min:	3 200 mm	126 in
	Max:	4 700 mm	185 in
Track shoe options	Width:	800/900/1 000 mm	31½/35½/39½ in
	Surface:	3-edge / flat edges / flat	
	Edge type:	normal / chamfer / bended	

Accessories

* Side cathead			* iPiler PCD
* Side auger	JD1,5		* Air conditioning
* Rear support legs			* Leader hinge

* Contact Junttan sales for all available options and accessories

Transport Dimension

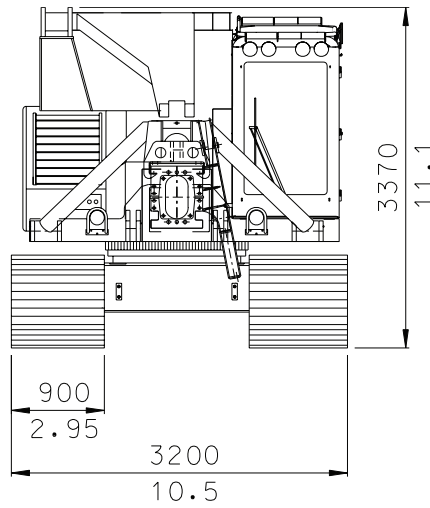

Minimum track width.

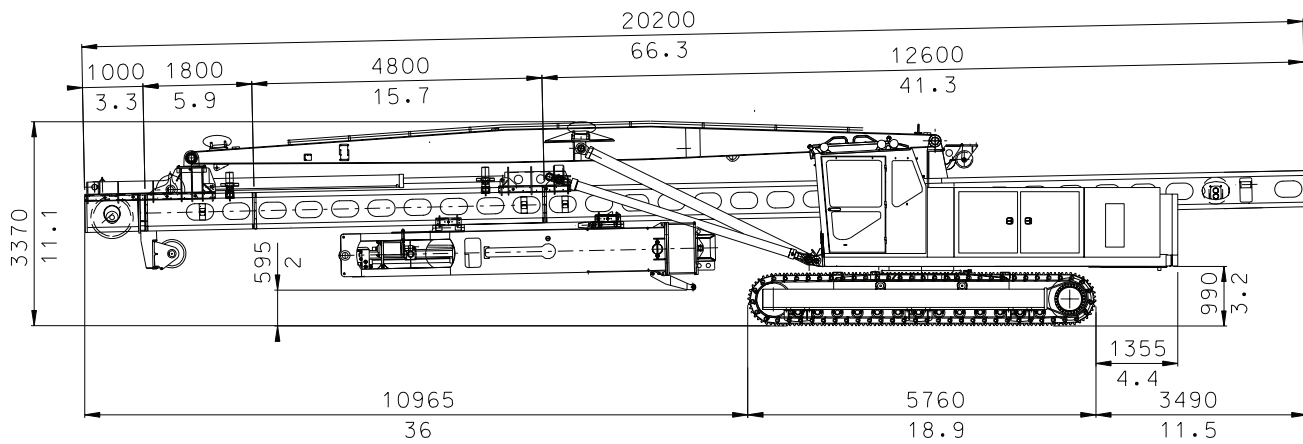

Standard PM23 transport dimensions with HHK 4A hammer.

Junttan

Junttan Oy
 P.O. Box 1702 (Matkuksentie 7)
 FI-70701 KUOPIO, Finland

Tel. +358 10 195 221
 Fax +358 17 287 4411
 junttan@junttan.com