

Hydraulic Impact Hammer

SHK 100-3

SHK 100-3/4
SHK 100-3/4/5
SHK 100-3/5
SHK 100-3/4/5/6

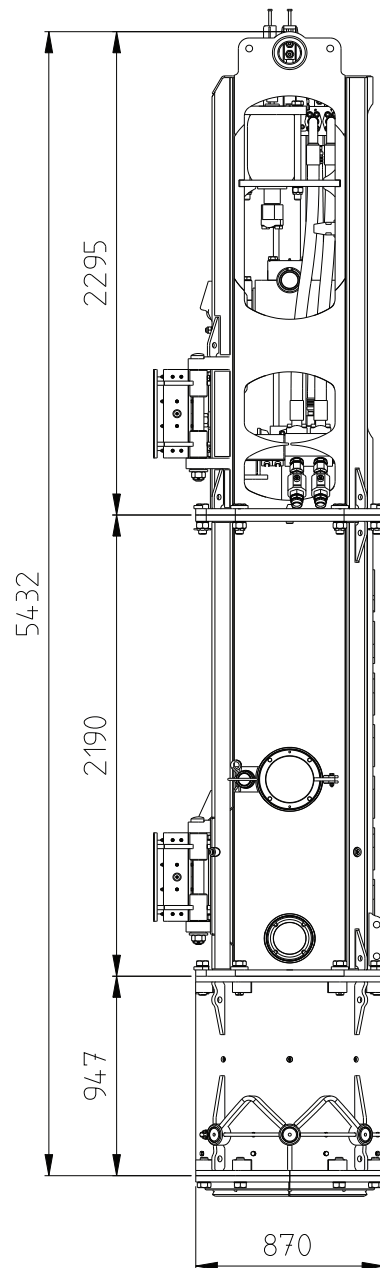
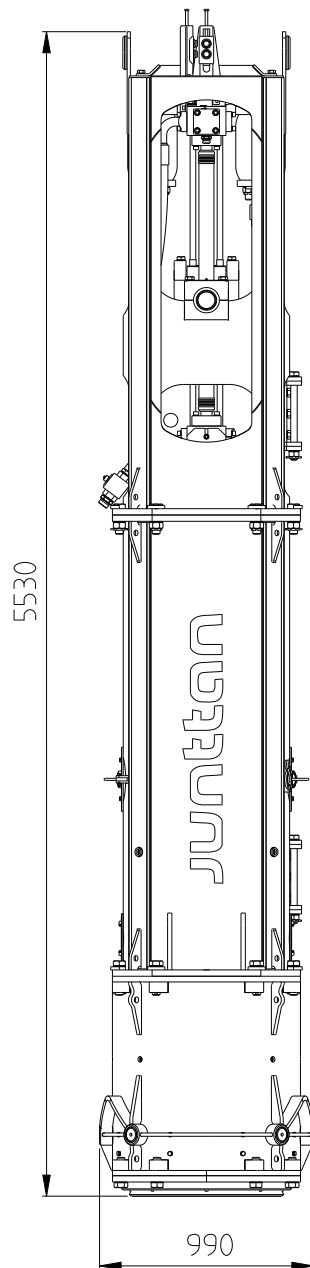

JUNTTAN SHK 100-3

Max. energy		36 kNm	26 907 ft-lb
Max drop height		1,2 m	3.94 ft
Blows per minute		60 – 140 +	60 – 140 +
Ram weight		3 000 kg	6 614 lb
Total weight			
	including noise insulation	6 920 kg	15 256 lb
	without noise insulation	6 560 kg	14 462 lb
Oil flow		381 l/min	101 gpm
Operating pressure		146 bar	2 118 psi
Theoretical power output		93 kW	126 hp
Hoses			
	– pressure line	38 mm	1 ½ inch
	– return line	38 mm	1 ½ inch
Drive cap housing (std)	Ø:	800 mm	31.5 inch
Drive cap types	A-type:	for metal tubes	for metal tubes
	B-type:	for concrete piles	for concrete piles
Drive cap max. inner diameter	A-type:	Ø 770 mm	23.6 inch
	B-type:	□ 470 x 470	18.5 x 18.5
Larger drive cap diameters available on special request			
Suitable Piling Rigs		PMx20, PMx22, PMx24, PM23	PMx20, PMx22, PMx24, PM23
Suitable Powerpacks		10XCU, 15CCU – 30CCU	10XCU, 15CCU – 30CCU

Accessories

* Guide claws			* Lifting cat
* Extensions			* Flying leader
* Energy measurement device			* Additional noise insulation package
* Additional drive caps			* Powerpacks
* Pile sleeves			

Technical details with extensions

JUNTTAN SHK 100-3/4-6	4T	5T	6T	4T	5T	6T	
Max. energy	49 kNm	61 kNm	73 kNm	35 876 ft-lb	44 845 ft-lb	53 814 ft-lb	
Max drop height	1,2 m	1,2 m	1,2 m	3.94 ft	3.94 ft	3.94 ft	
Blows per minute	60 – 140 +	60 – 140 +	60 – 140 +	60 – 140 +	60 – 140 +	60 – 140 +	
Ram weight	4 000 kg	5 000 kg	6 000 kg	8 818 lb	11 023 lb	13 228 lb	
Total weight							
	including noise insulation	8 120 kg	9 250 kg	10 430 kg	17 902 lb	20 393 lb	22 994 lb
	without noise insulation	7 760 kg	8 890 kg	10 070 kg	17 108 lb	19 599 lb	22 201 lb
Oil flow	381 l/min	381 l/min	381 l/min	101 gpm	101 gpm	101 gpm	
Operating pressure	194 bar	243 bar	292 bar	2 814 psi	3 524 psi	4 235 psi	
Theoretical power output	123 kW	154 kW	185 kW	168 hp	210 hp	252 hp	
Suitable Piling Rigs (PMx20, PMx22, PMx24, PM23)							
Suitable Powerpacks (10XCU, 15CCU – 30CCU)							

Junttan

Junttan Oy
P.O. Box 1702 (Matkusentie 7)
FI-70701 KUOPIO, Finland

Tel. +358 10 195 221
Fax +358 17 287 4411
junttan@junttan.com