

Hydraulic Impact Hammer

HHK16S

HHK16/18S

HHK16/20S

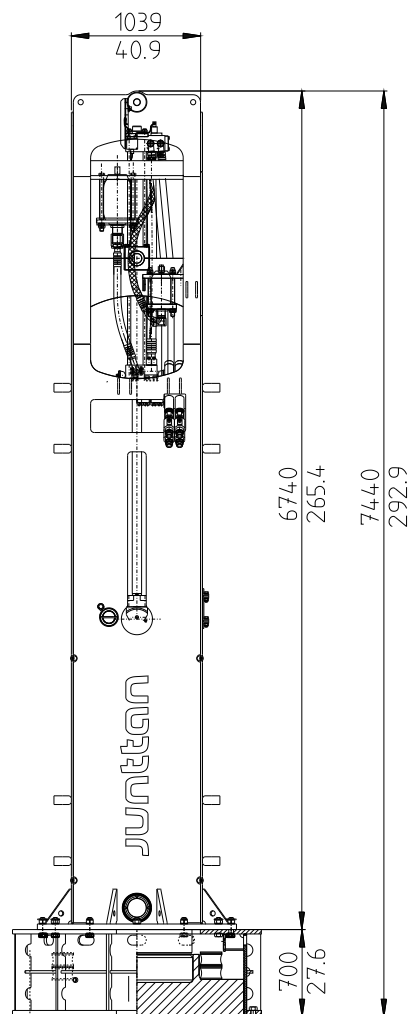
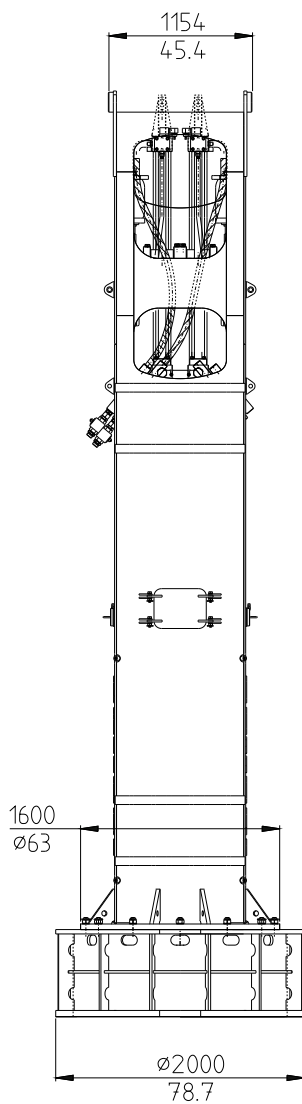

JUNTTAN HHK16S

Max. energy		235 kNm	173 592 ft-lb
Max drop height		1,5 m	4.92 ft
Blows per minute		30 - 100	30 - 100
Ram weight		16 000 kg	35 274 lb
Total weight	including A-type drive cap	29 700 kg	65 468 lb
Oil flow		657 l/min	174 gpm
Operating pressure		231 bar	3 350 psi
Theoretical power output		253 kW	344 hp
Hoses			
	- pressure line	2 x 38 mm	2 x 1 ½ inch
	- return line	2 x 38 mm	2 x 1 ½ inch
Drive cap housing (std)	Ø:	1720 mm	67,7 inch
Drive cap types	A-type:	for metal tubes	for metal tubes
	B-type:	for concrete piles	for concrete piles
Drive cap max. inner diameter	A-type:	Ø 1 600 mm	63.0 inch
	B-type:	<input type="checkbox"/> by special request	by special request
Larger drive cap diameters available on special request			
Suitable Powerpacks		15CCU - 30 CCU	15CCU - 30 CCU

Accessories

* Guide claws			* Lifting cat
* Extensions			* Flying leader
* Energy measurement device			* Additional noise insulation package
* Additional drive caps			* Powerpacks
* Pile sleeves			

Technical details with extensions

JUNTTAN HHK16/18S 16/20S	18T	20T	18T	20T	
Max. energy	265 kNm	294 kNm	195 291 ft-lb	216 990 ft-lb	
Max drop height	1,5 m	1,5 m	4.92 ft	4.92 ft	
Blows per minute	30 - 100	30 - 100	30 - 100	30 - 100	
Ram weight	18 000 kg	20 000 kg	39 683 lb	44 092 lb	
Total weight	including A-type drive cap	32 471 kg	34 856 kg	71 586 lb	76 844 lb
Oil flow	657 l/min	657 l/min	657 gpm	657 gpm	
Operating pressure	260 bar	289 bar	3 771 psi	4 192 psi	
Theoretical power output	285 kW	316 kW	387 hp	430 hp	
Suitable Powerpacks	20 CCU - 30 CCU	20 CCU - 30 CCU	20 CCU - 30 CCU	20 CCU - 30 CCU	

Junttan

Junttan Oy
P.O. Box 1702 (Matkuksentie 7)
FI-70701 KUOPIO, Finland

Tel. +358 10 195 221
Fax +358 17 287 4411
junttan@junttan.com