

Junttan

Hydraulic Impact Hammer

HHK 14A

HHK 14/16A

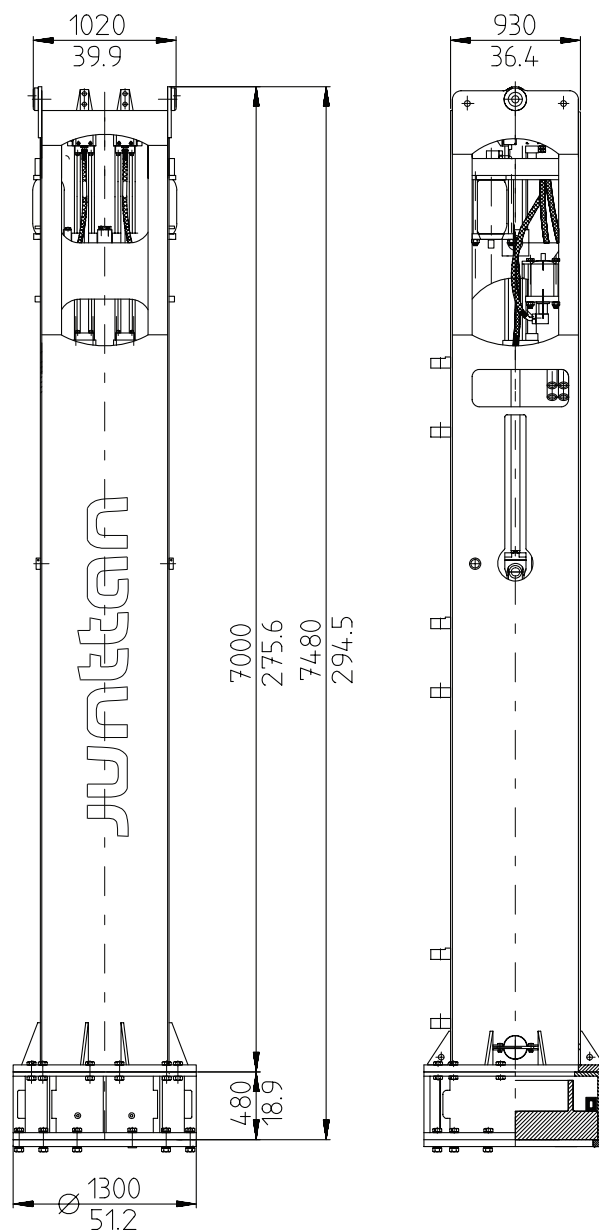

Original
Junttan
product

DATA SHEET

JUNTTAN HHK 14A

Max. energy		165 kNm	121 151 ft-lb
Max drop height		1,2 m	3,94 ft
Blows per minute		40 – 100	40 – 100
Ram weight		14 000 kg	30 865 lb
Total weight	including A-type drive cap	22 500 kg	49 604 lb
Oil flow		795 l/min	210 gpm
Operating pressure		183 bar	2 654 psi
Theoretical power output		242 kW	330 hp
Hoses			
	- pressure line	2 x 38 mm	2 x 1 ½ inch
	- return line	2 x 38 mm	2 x 1 ½ inch
Drive cap housing (std)	Ø:	1 080 mm	42.5 inch
Drive cap types	A-type:	for metal tubes	for metal tubes
	B-type:	for concrete piles	for concrete piles
Drive cap max. inner diameter	A-type:	Ø 1 050 mm	41.3 inch
	B-type:	<input type="checkbox"/> by special request	by special request
Larger drive cap diameters available on special request			
Suitable Powerpacks		15CCU – 30CCU	15CCU – 30CCU

Accessories

* Guide claws			* Lifting cat
* Extensions			* Flying leader
* Energy measurement device			* Additional noise insulation package
* Additional drive caps			* Powerpacks
* Pile sleeves			

Technical details with extensions

JUNTTAN HHK 14/16A

16T**16T**

Max. energy		188 kNm	138 874 ft-lb
Max drop height		1,2 m	3,94 ft
Blows per minute		40 – 100	40 – 100
Ram weight		16 000 kg	35 274 lb
Total weight	including A-type drive cap	27 400 kg	60 407 lb
Oil flow		795 l/min	210 gpm
Operating pressure		209 bar	3 031 psi
Theoretical power output		277 kW	377 hp
Suitable Powerpacks		15CCU – 30CCU	15CCU – 30CCU

JUNTTAN

Junttan Oy
P.O. Box 1702 (Matkuksentie 7)
FI-70701 KUOPIO, Finland

Tel. +358 10 195 221
Fax +358 17 287 4411
junttan@junttan.com